

Contents

1. Product Introduction	2
1.1 User guide	2
1.2 Wiring diagram with access power	3
1.3 Wiring diagram with normal power	3
1.4 Keypad	4
2. Setting Guide	4
2.1 Program Mode (admin password)	4
2.2 Change admin password	5
2.3 Register normal user's finger (card)	5
2.4 Register normal user's password	6
2.5 How to open lock	6
2.6 Register admin finger(card)	6
2.7 Delete user (Single delete)	7
2.8 Delete all user	7
2.9 Control lock signal restoration time	8
2.10 Backup users' information to U flash drive	8
2.11 Recover users' information in u flash drive to access device	8
2.12 Restore factory default	9
2.13 Set the device NO	9
2.14 Date setting (year/month/date)	9
2.15 Time setting (h/m/s)	10
2.16 Export the attendance record to U flash drive	10
2.17 Export history attendance record to U flash drive	11
2.18 Upgrade (Use U flash drive)	11
2.19 Clear all the admin enroll information	11
2.20 Initialization	12
3. User verification	12

1. Product Introduction

1.1 User Guide

This is a new standalone version fingerprint access control device, you can use fingerprint and card to verify. It is very easy to operate, the wiring terminal is the same as the standalone fingerprint access device on the market. User can use this device instead of the card access device or password access device, with that you don't need to change anything. Please use access control power and install it away from the rain. Please don't leave the equipment in the light shine and don't strike it

Specification

Scanner: Optics glass

FAR: $\leq 0.0001\%$

FRR: $\leq 0.01\%$

Recognition speed: $< 1.5s$

Recognition way: 1:N

Fingerprint capacity: 500

Storage capacity: 100000

Communication way: Fingerprint, ID card(Em125khz)

Report: U flash drive to export a TXT file

Keypad: 15

Access port: 9 digit (power input/ control the lock/ switch/ doorbell)

Indicate light: red, green and buzzer

Size: 170*65*50MM

1.2 Wiring diagram with access power

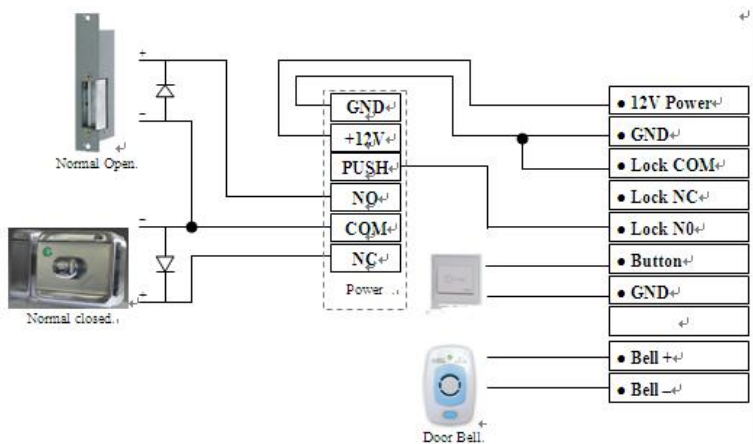

1.3 Wiring diagram with normal power

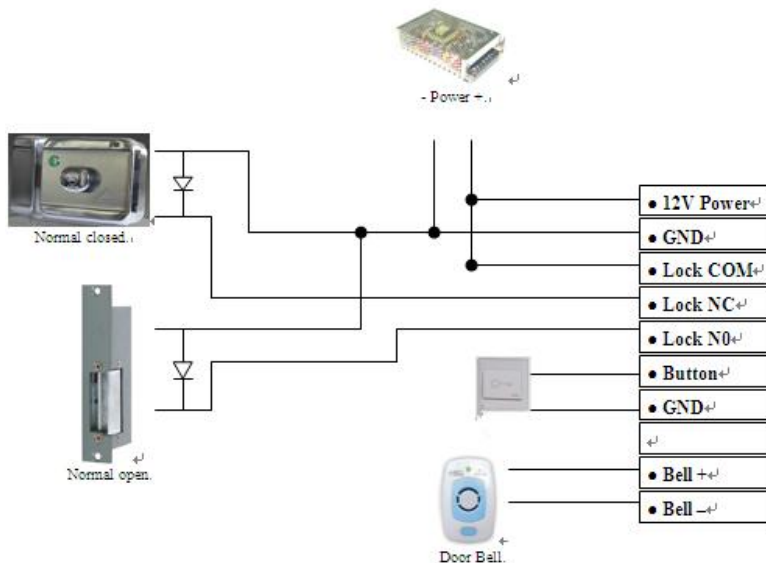

1.4 Keypad



1	No. key 1	8	No. key 8
2	No. key 2	9	No. key 9
3	No. key 3	0	No. key 0
4	No. key 4	*MENU	Set
5	No. key 5	# ENTER	OK
6	No. key 6	IN	In statue keypad
7	No. key 7	OUT	Out statue keypad
		Bell icon	Door bell

Note:

1. The initial admin. password : 1234
2. User must use admin. password to enter the program status, before the admin. finger or password are not set.
3. In program status, please continuous to press * twice, the device will back to the normal working state.
4. In program status, if there is no any operate, the device will automatic back to the normal working state.

2. Setting Guide

2.1 Program Mode (use admin password)

*	#	1234	#	Success=> buzzer ring 1time,the green light show
---	---	------	---	--

The initial administrator's password is 1234, user can change it by themselves.

2.2 Change admin password

*#1234#	0	xxxx	#	xxxx	#	Success=> buzzer ring 1time,the green light show
---------	---	------	---	------	---	--

xxxx: means 4 digit decimalism admin password, the password must be inputted the same at two times.

2.3 Register normal user's fingerprint (card)

The register step

*#xxxx#	1	***	#	Press fingerprint or card 3 times	Success=> buzzer ring 1time,the green light show
---------	---	-----	---	-----------------------------------	--

xxxx: means 4 digit decimalism admin password

***: means 3 digit decimalism use's ID NO.

Advice: when you register the use, please make a form:

No.	ID No.	Name	Reg. Date	Leave work date	Type
1	001	Jane	2015.02.20		Admin
2	002	Tom	2014.12.22		User

How to register finger?

1. User put their finger on the scanner
2. Press finger, when there is a green light, please leave on the scanner. Do this three times(the same fingerprint), then succeed.

Please pay attention the posture , look at the picture:



If you don't notice the register way, when you use it, the device can't identify your finger.

2.4 Register normal user's password

The register step

*#xxxx#	1	***	#	PPPP	#	PPPP	Success=> buzzer ring 1time,the green light show
---------	---	-----	---	------	---	------	---

xxxx: means 4 digit decimalism admin password

***: means 3 digit decimalism use's ID NO.

PPPP: 4 digit decimalism normal user's password.

2.5 how to open lock

1.1 Press finger or swipe card that have be enrolled.

1.2 Input the user's password that have be enrolled, such as:

***	#	PPPP	#	Success=> buzzer ring 1time,the green light show
-----	---	------	---	---

***: means 3 digit decimalism use's ID NO.

PPPP: means 4 digit decimalism normal user's password.

2.6 Register admin fingerprint or card

The register step

*#xxxx#	2	***	#	Press fingerprint 3 times or swipe card	Success=> buzzer ring 1time,the green light show
---------	---	-----	---	--	--

XXXX: means 4 digit decimalism admin password.

***: means 3 digit decimalism use's ID NO.

The administrator's finger or card can instead administrator's password to enter the program statue.

Step

*	#	Press admin fingerprint or swipe card	#	Success=> buzzer ring 1time,the green light show
---	---	---------------------------------------	---	--

Note: 1. The device only can add 5 administrators
2. Normal user must be delete first, then be enrolled to admin.

2.7 Delete user (Single delete)

Step

*#xxxx#	3	***	#	Success=> buzzer ring 1time, the green light show
---------	---	-----	---	---

XXXX means 4 digit admin password

*** means user's register No.

After delete a user, administrator can press finger or card to check whether the delete is success.

2.8 Delete all user

Step

*#xxxx#	4	xxxx	#	Success=> buzzer ring 1time, the green light show
---------	---	------	---	---

XXXX means 4 digit admin password

Note: This order will delete all the register information (fingerprint, card) in the device.

2.9 Control lock signal restoration time

Step

*#XXXX#	5	***	#	Success=> buzzer ring 1time,the green light show
---------	---	-----	---	--

XXXX means 4 digit admin password

*** means the restoration time of the unlock signal, the unit is second.

The range of the restoration time of the unlock signal: 1-255, time is second.

Initial value is 3s

2.10 Backup users' information to U flash drive

Step

*#XXXX#	6	#	Light off, wait for a few seconds	Success=> buzzer ring 1time,the green light show
---------	---	---	-----------------------------------	--

XXXX means 4 digit admin password, before operation, please make sure the u flash drive is insert in the USB port on the device. The system form from the U flash drive file must be FAT32.

There will be a data file 100_AFP.dat when you finish the backup, all the fingerprint information from the device is in this file.

2.11 Recover users' information in u flash dive to access device

Step

*#XXXX#	7	#	Light off, wait for a few seconds	Success=> buzzer ring 1time,the green light show
---------	---	---	-----------------------------------	--

XXXX means 4 digit admin password, before operation, please make sure

the u disk is insert in the USB port on the device. The system form from the U flash drive file must be FAT32.

This order can recover the user's information (fingerprint or card) in the U flash drive file  to the device.

2.12 Restore factory default

Step

*#xxxx#	8	#	Light off, wait for a few seconds	Success=> buzzer ring 1time,the green light show
---------	---	---	-----------------------------------	--

This order can recover the parametric in the device to initialize status. This order will not lose the user register information (fingerprint or card).

2.13 Set the device No.

Step

*#xxxx#	91	***	#	Success=> buzzer ring 1time,the green light show
---------	----	-----	---	--

XXXX means 4 digit admin password

*** means the device No.

The range of the device No.: 001-999, factory default: 001.

2.14 Set the device date (year/month/date)

Step

*#xxxx#	92	YYYY MMDD	#	Success=> buzzer ring 1time,the green light show
---------	----	--------------	---	--

Set the device date (year/month/date), for example: 2015/1/1, press the keypad:
9220150101#

2.15 Set the time (h/m/s)

Step

*#xxxx#	93	HHMM SS	#	Success=> buzzer ring 1time,the green light show
---------	----	------------	---	--

Set the device time (h/m/s), for example: 17:25:32,

press the keypad: 93172532#

2.16 Export the attendance record to U flash drive

Step

*#xxxx#	94	#	Light off, wait for a few seconds	Success=> buzzer ring 1time,the green light show
---------	----	---	-----------------------------------	--

XXXX means 4 digit admin password, before operation, please make sure the u flash drive is insert in the USB port on the device. The system form from the U flash drive file must be FAT32.

Every time user identify their fingerprint or card to open the door, there will be an record. This order can export the attendance record in the device to u flash drive and become a data file "001_ GLog.TXT". And this order only can export the attendance record after last time user exported. The date in the file is

No	Mcn	EnNo	Mode	Date	Time
000001	1	001	0	2015/03/25	16:12:00
000002	2	002	0	2015/03/25	16:14:00
000003	3	003	0	2015/03/25	16:16:00

2.17 Export history attendance record to U flash drive

Step

*#xxxx#	95	#	Light off, wait for a few seconds	Success=> buzzer ring 1time,the green light show
---------	----	---	-----------------------------------	--

XXXX means 4 digit admin password, before operation, please make sure the u flash drive is insert in the USB port on the device. The system form from the U flash drive file must be FAT32.

This order can export all the attendance record (with record that has been exported) in the device and become a data file "001_ GLog.TXT", and this date form in the file is the same as the file "001_ GLog.TXT".

Note: The storage capacity is 100000, the earliest record will be automatic covered if the record is exceed the storage capacity.

2.18 Upgrade (Use U flash drive)

Step

*#xxxx#	99	#	Light off, wait for a few seconds	Success=> buzzer ring 1time,the green light show
---------	----	---	-----------------------------------	--

Before operation, please make sure the u disk is insert in the USB port on the device. The system form from the U flash drive file must be FAT32.

2.19 Clear all the admin register information

Step

*#19841212##	Success=> buzzer ring 1time,the green light show
--------------	--

This order will clear all the admin register information in the device and initialize the admin password to 1234.

2.20 Initialization

Step

Clear all the record	2.8 Delete all user
Restore factory default	2.12 Restore factory default
Clear all the admin	2.19 Clear all the admin register information

3. User verification

After link with the power, the device is in the identify status, user can identify and open the lock.

